



Dual-Lite[®] Trident TRF Remote Status Panel

10 to 60kVA

USER MANUAL



No reproduction of any part of this manual, even partial, is permitted without the authorization of Dual-Lite. Dual-Lite reserves the right to modify the product described herein, in order to improve it, at any time and without notice.

For technical assistance, contact Dual-Lite's Technical Support Center at 1-800-848-6439. Technicians are available during normal working hours (EST).

Hubbell Lighting, Inc
701 Millennium Blvd
Greenville, SC 29607
Web site: www.dual-lite.com

Thank you for choosing our product.

Table of Contents

Physical Characteristics..... 1
Installation 1
Operating Instructions2
Front Panel LED & Audible Alarm Summary.....3

Figure 1.0 Front View, LED callout.....4
Figure 2.0 TB1 Connections.....5
Figure 3.0 UPS Alarm Connections.....5
Figure 4.0 Internal View6
Figure 5.0 Dimensions7

Physical Characteristics

Weight: 10lbs (4.5kgs.)
Height: 8 1/4 inches (210 mm)
Width: 8 5/16 inches (211mm)
Depth: 4 5/16 inches (110 mm)

Installation

1. Locate the area where the Remote Status Panel (RSP) will be installed. The monitor should be within 1,500 feet (500 meters) of the UPS.
2. Mount the monitor to the wall using the four pre-drilled holes in the back. Use appropriate hardware for the installation. See **Figure 4.0** for mounting locations.
3. Wiring requirements are: 6 twisted pair 16 AWG cable run in metal conduit. Belden Catalog No. 1485 (8 twisted pair) or equivalent. All electrical and mechanical connections to be made per local and/or national electric codes. Connect the conduit to the RSP by punching the appropriately sized hole in a convenient location. See **Figure 5.0** for conduit locations.

Caution! Care should be taken not to damage any internal components when drilling hole for conduit.

4. Connect the six (6) pairs of twisted wire from the RSP to the customer accessible alarm contact terminal bar in the UPS module. See **Figure 2.0**, **Figure 3.0**, **Figure 4.0**, and the corresponding UPS wiring diagram for wiring connections. (Refer to the UPS' owner's manual for location)
5. Install (6) AA batteries (included). Batteries will provide about 8 hours of run time in the event of an AC power failure. See **Figure 4.0** for battery location. Replace these batteries yearly for optimum performance.
6. Connect the power supply adapter into the corresponding jack located on the bottom left-hand side of the RSP enclosure. Plug the power supply into a convenient 120V/60Hz wall receptacle. See **Figure 4.0** Internal view. Failure to connect to a suitable wall outlet will drain the RSP's internal batteries and/or result in damage to the monitor.

Caution! The monitor must be installed by a qualified electrician. The Installation is to be inspected by an Authorized UPS Service Engineer at the time of UPS startup.

Operating Instructions

ALARM SILENCE pushbutton is used to silence the alarm.

MONITOR RESET pushbutton is used to reset the RSP'S UPS FAULT alarm. The monitor will alarm again if the alarm condition is still present following the RESET.

Monitor TEST pushbutton is used to check the operation of all LED's and the audible alarm. All LED's that are illuminated will go off and all lights that are off will illuminate. Horn will also sound.

INTERNAL MONITOR BATTERY TEST button is used to test the condition of the monitor's battery pack. If the yellow LED does not illuminate, replace the batteries.

Reset the RSP as follows:

1. On the UPS, note the alarm and its fault code. See UPS manual for fault codes.
2. If no alarm code is present, press the monitor reset button.
3. If the monitor's audible alarm sounds again repeat steps 1 and 2.
4. Contact Dual-Lite's Technical Support Center if the alarm cannot be reset after a few attempts.

Front Panel LED & Audible Alarm Summary

Refer to **Figure 1.0** for the location of the LED's and pushbuttons described below:

Normal Operation: When the Input, Rectifier, Inverter, and Output green LEDs are lit.

1. **Rectifier / Charger LED:** This green LED is illuminated as long as the Rectifier Charger is operating in the UPS.
2. **Battery LED:** This yellow LED is illuminated as long as the UPS is on Battery. The audible alarm will also beep intermittently.
3. **Inverter On LED:** This green LED is illuminated as long as the inverter is operating in the UPS.
4. **Output LED:** This green LED is illuminated as long as there is power to the critical load. (either by the Inverter or Bypass)
5. **Load On Bypass LED:** This yellow LED is illuminated as long as the critical load is powered by the Bypass.
6. **AC Input LED:** This green LED is illuminated as long as there is AC power supplied to the system.
7. **UPS Fault:** This Red LED is illuminated and the audible alarm sounds when a UPS fault has occurred. After the fault has cleared, the monitor must be reset.
8. **Over Temp LED:** This red LED is illuminated and the audible alarm sounds when a UPS over temperature has occurred.
9. **Input Failure LED:** This red LED is illuminated and the audible alarm sounds when there is an Input power outage.
10. **Battery Low Voltage:** This red LED is illuminated and the audible alarm sounds as soon as the DC bus voltage approaches its cutoff voltage.
11. **Alarm Silence LED:** This red LED will stay illuminated if the alarm silence button has been pressed and alarm condition is still present. If the alarm condition clears, the alarm silence LED will automatically reset.
12. **Internal Monitor Battery OK LED:** This yellow LED will illuminate when its corresponding push button is pressed and the batteries are OK. If this light is dim or does not light replace all internal batteries.

Note: When all contacts from the UPS are open, the Input Failure LED will be on.

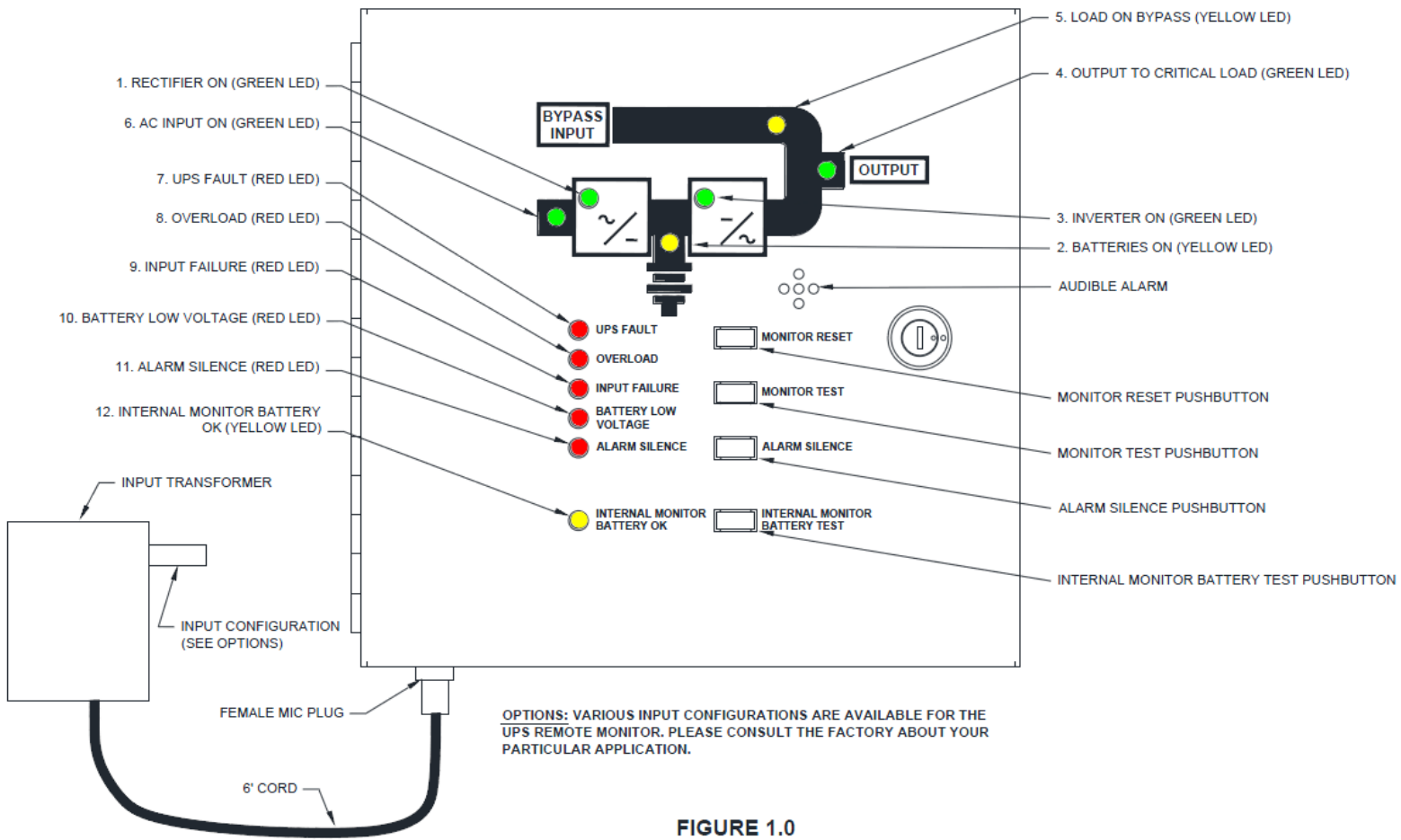

FIGURE 1.0

Figure 1.0 Front View, LED callout

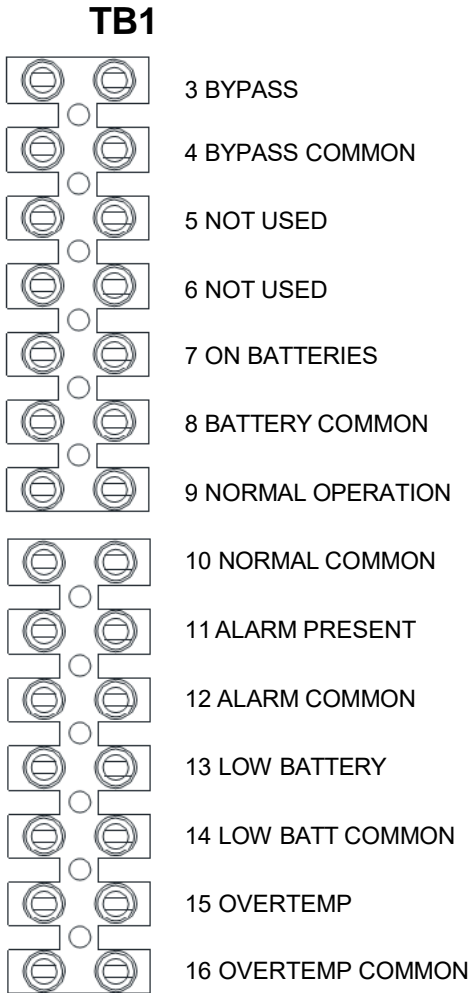

Figure 2.0 TB1 Connections

UPS Wiring Table:

Alarm	Connection	TB1 Connection	Description
Bypass	N.C. COM	Pin 3 Pin 4	Closes when in Bypass
Not Used	N.C. COM	Pin 5 Pin 6	Not used
On Battery	N.C. COM	Pin 7 Pin 8	Closes when On Batteries
Normal Operation	N.C. COM	Pin 9 Pin 10	Closes when in Normal Operation
Alarm Present	N.C. COM	Pin 11 Pin 12	Closes when Alarm Present
Low Battery	N.C. COM	Pin 13 Pin 14	Closes when Batteries are Low
Over Temp	N.C. COM	Pin 15 Pin 16	Closes when Over Temperature

Figure 3.0 UPS Alarm Connections

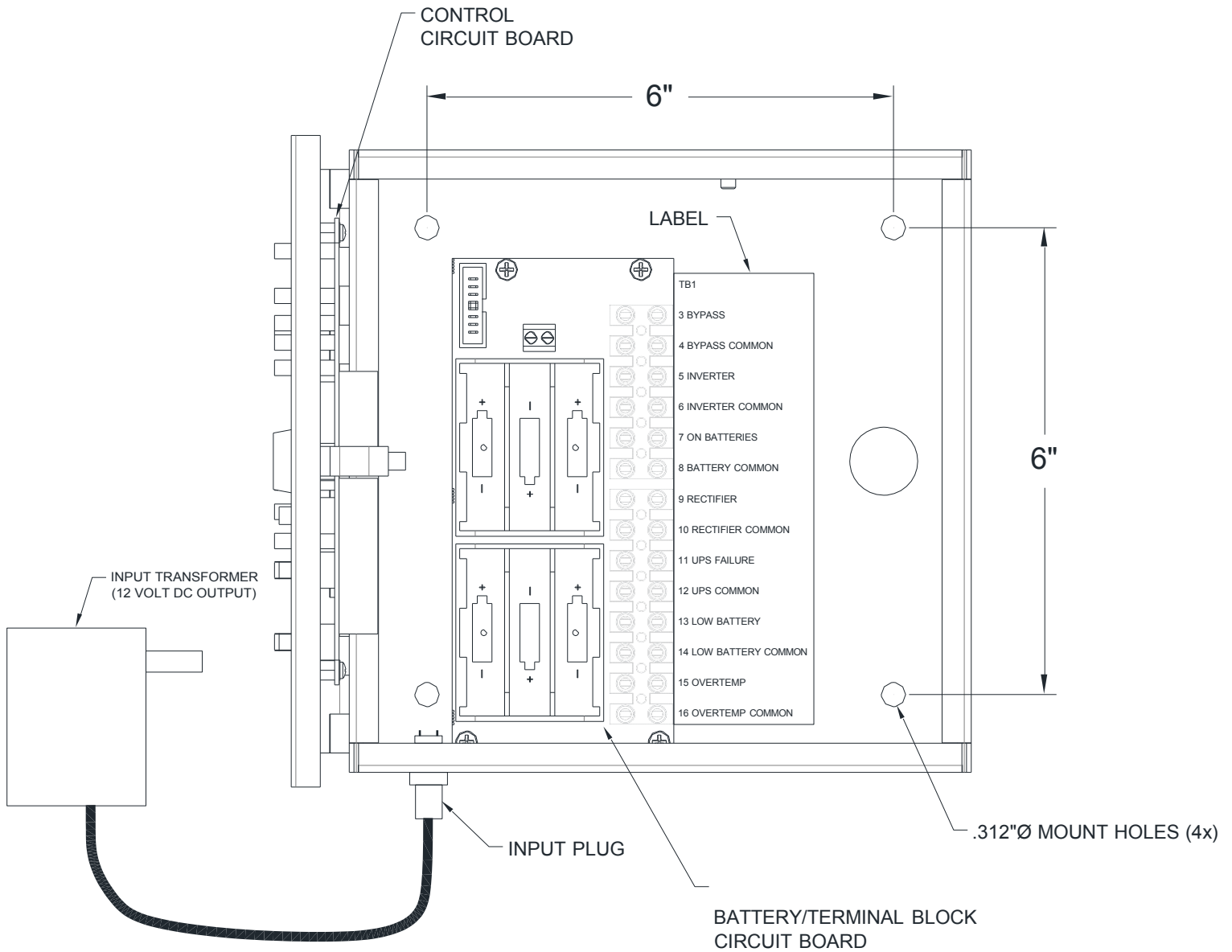

Figure 4.0 Internal View

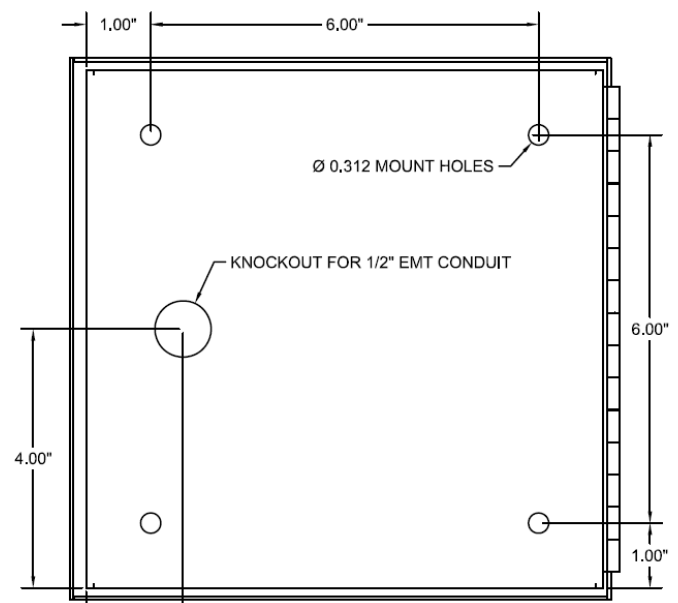
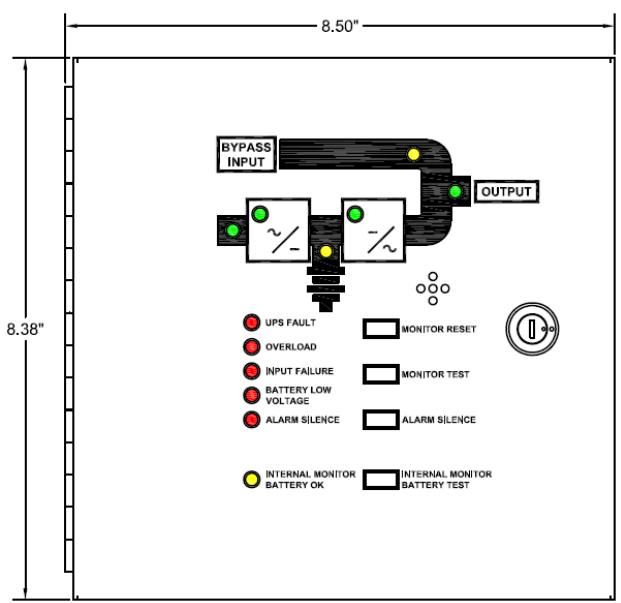
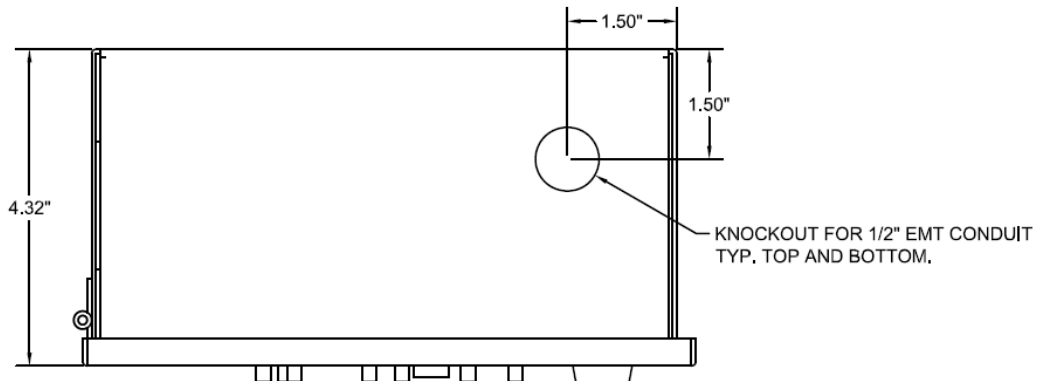

Figure 5.0 Dimensions